



AUTOMATIC ENTRANCE SPECIALISTS



QIKLUX

IP1916
rev. 2007-01-30

I Manuale di installazione kit luci per barriera.

GB Installation handbook for barrier lights kit.

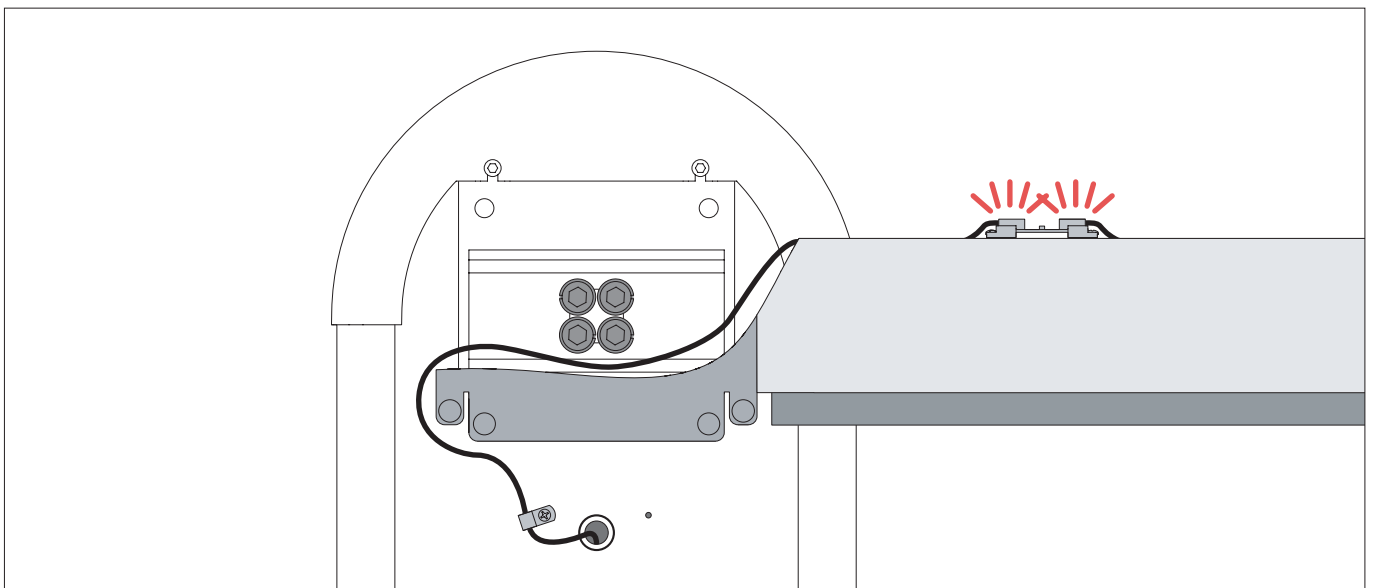
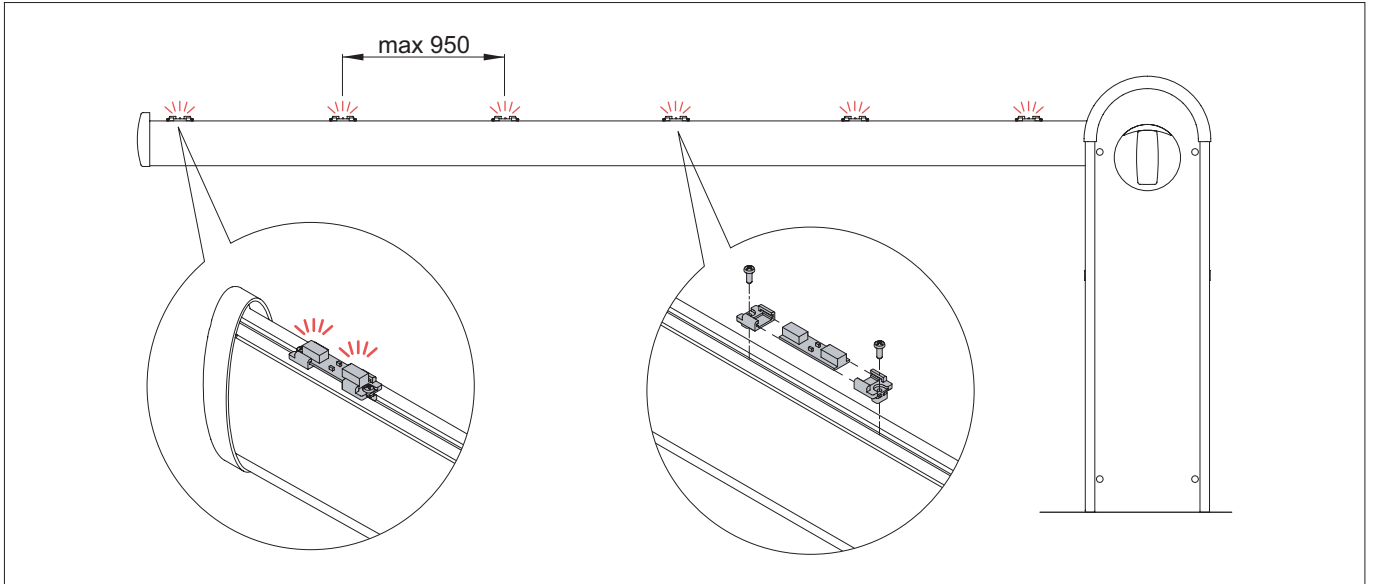

*N.B.: per i collegamenti elettrici fare riferimento al manuale del quadro elettronico.
Note: for the electrical connections refer to the control panel manual.*



DITEC S.p.A.
Via Mons. Banfi, 3 - 21042 Caronno Pertusella (VA) - ITALY
Tel. +39 02 963911 - Fax +39 02 9650314
www.ditec.it - ditec@ditecva.com

ISO 9001
Cert. n° 0957