

SAFE

**24V**  
ENCODER

VERSATILE

SETTING



## **Ditec QiK**

EN

Automatic barriers for passages up to 7.6 m

# Ditec Qik

Ditec Qik is the top performance automatic barrier that fits perfectly into any context. It is the ideal solution for completely secure access control and management, allowing only authorised personnel to enter.

## COMPLETE PEACE OF MIND, safe and long lasting

- **base plate with anchoring clamps** to secure the cabinet solidly and firmly to the ground
- **stainless steel rivets without welding** remain unchanged over time
- **electronic anti-frost system** that guarantees the efficiency of the motor even at low temperatures
- **battery operation:** in the event of a blackout, the control panel is powered by batteries to ensure proper operation of the automation system, also essential in areas where the power supply is not always guaranteed
- **single-block die-cast gear reducer** for simple assembly and greater durability
- in the event of disturbance/interference, **433 MHz and 868 MHz** frequencies are available
- **opening to the right or left** by simply changing the spring position
- **balancing system** that uses a single spring that works by compression

## VERSATILE to meet all requirements

Ditec Qik also includes a series of accessories:

- **bar with joint** for installing the barrier where height is limited when opening and does not allow the bar to move vertically (e.g. underground car parks)
- **LED bar lighting kit** to make obstacles visible and to indicate the automation system status: the LED is off when the bar is open, flashing during movement and steady on when the bar is closed
- **electro-mechanical lock** to guarantee greater safety and protection from undesirable openings
- **key-protected release lever** accessed quickly on the inspection side
- designed to accommodate **assembly of photocells inside the cabinet**

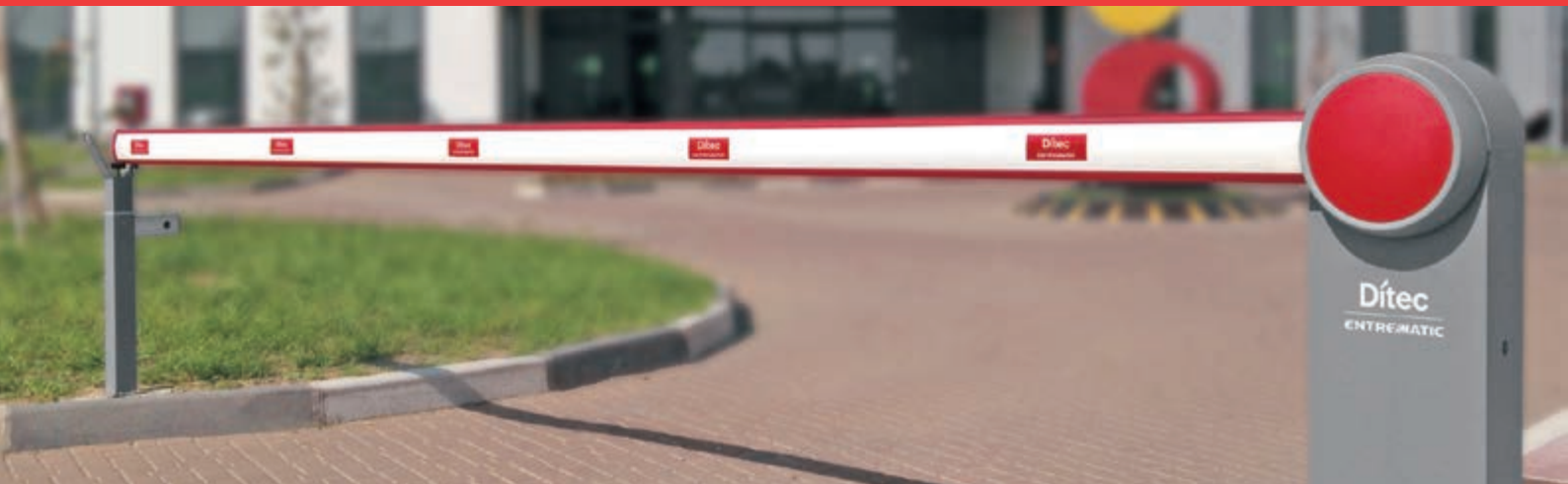

## OUR EXPERTISE AT YOUR SERVICE

A complete range. A dedicated team of specialists. Excellent technology and design. Passionate to be different.

Entrematic is a commercial partner with a complete range in the entrance-automation sector, which combines specialised know-how and high-profile brands.

The Ditec brand, has been a world leader for more than 40 years, offering a complete range of automation systems for gates, automatic doors and high-speed doors.

**Normstahl**  
ENTRE/MATIC

**DYNACO**  
ENTRE/MATIC

**NERGECO**  
ENTRE/MATIC

**Ditec**  
ENTRE/MATIC

**em**  
ENTRE/MATIC

**Amarr**  
ENTRE/MATIC

**KELLEY**  
ENTRE/MATIC

**SERCO**  
ENTRE/MATIC

# Ditec Qik | 7EH



Aluminium elliptic arm for openings ranging from 1.3 m to 5.8 m

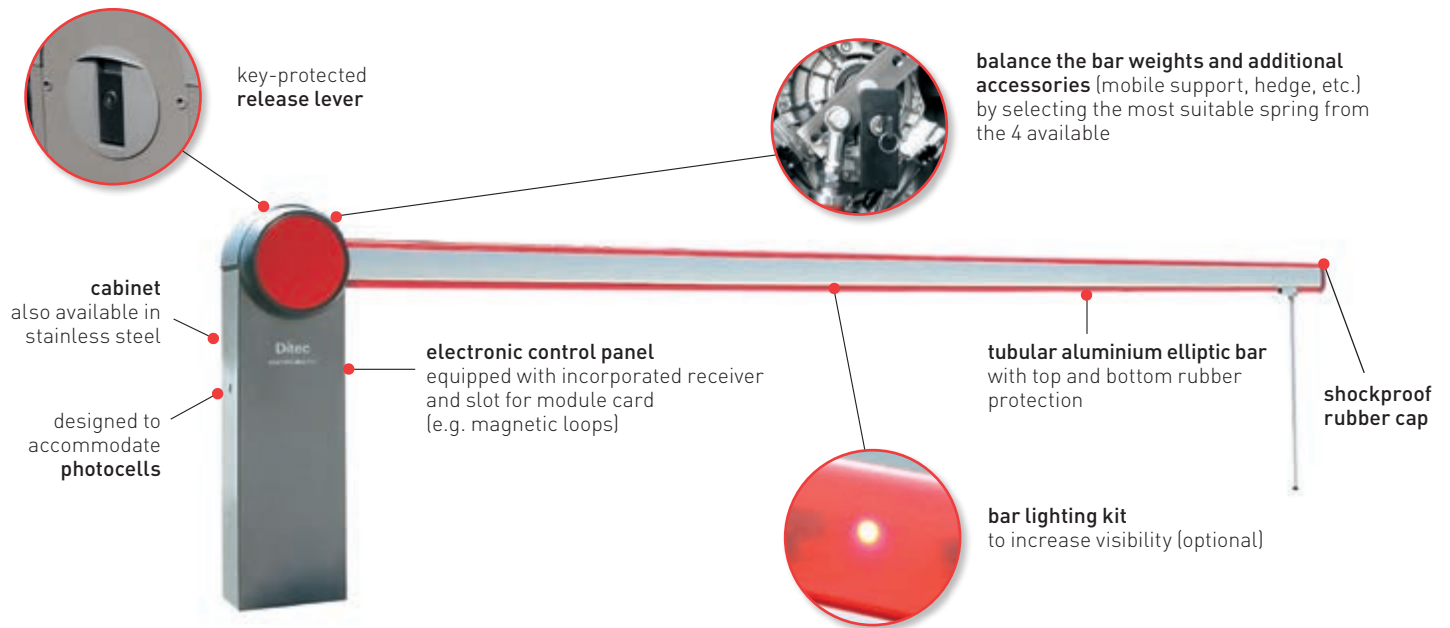

## SETTINGS

adjustment made simple

- trimmers for an easy speed adjustment during opening, closing and for automatic closing time
- force and braking space adjustment
- memory module for storing remote controls: if the control panel is replaced, the memory module can be mounted in a new control panel
- LED diagnostics on the control panel

## MANAGE CAR PARKS

that are bidirectional

**Ideal solution for car parks with bidirectional access:** access to the car park following authorisation or payment (e.g. coin box) while exit is free.

**With the M1QKC7 accessory, the barrier recognises the transit direction of the vehicle:** it disables the auxiliary control (exit magnetic loop) after releasing the safety device (e.g. photocells) only for incoming vehicles

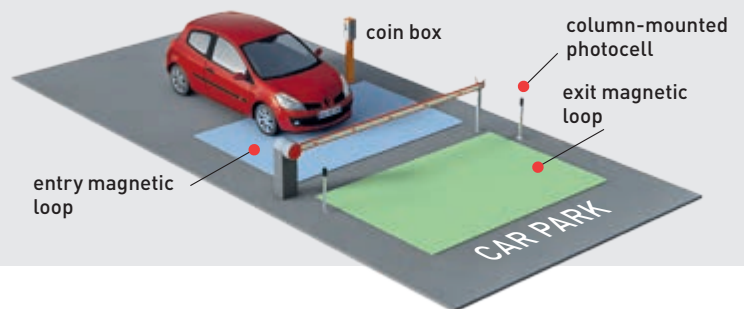

## FULL COMPLIANCE WITH EU DIRECTIVES AND STANDARDS



- 2014/30/EU - EMCD - Electromagnetic Compatibility Directive
- 2014/53/EU - RED - Radio Equipment Directive
- 2006/42/CE - Machinery directive: (Annex II-B; Annex II-A; Annex I-chapter 1)
- Harmonised EU Standards: EN 60335-1; EN61000-6-3; EN61000-6-2; ETSI EN 300 220-2; ETSI EN 301 489-1; ETSI EN 301 489-3
- Other standards / technical specifications applied: EN12445; EN62233; EN55014-1
- Wind resistance class: class 5

# Ditec Qik | 80EH

Aluminium round arm for openings ranging **up to 7.6 m**

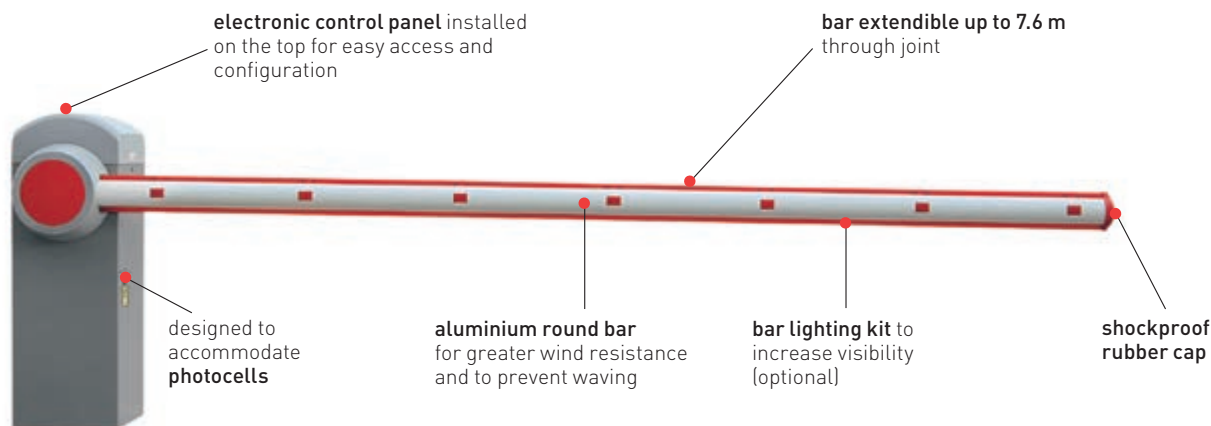

## AUTOMATION SYSTEM

with guaranteed periodic servicing

- **total operation counter** keeps track of the total number of cycles carried out by the operating device
- **partial operation counter** (can be reset) to program a maintenance threshold at which the flashing light will tell your customer that it's time to carry out servicing!

## DUAL CONFIGURATION MODE:

basic and advanced

Quick setting using the trimmer, or **precise setting of all parameters by connecting the MD2 display module to the control unit.**

- **adjustment of thrust** on obstacles
- **speed setting** during opening, closing and for automatic closing time
- **acceleration time adjustment**
- **slowdown setting** during opening and closing
- **complete management of remote control memory module** (storage or deletion of a remote control, total deletion, setting functions for each channel)
- **pre-flashing time** during opening and closing
- **renewal of automatic closing time** after the safety device is released

## AND IF THIS IS NOT ENOUGH

- **low battery warning**, battery disengagement voltage threshold setting
- **removable storage** allows operating settings to be saved and copied to another operating device
- **terminal for connecting two barriers** in a master/slave configuration so the dual opening or interlocking openings control is synchronised
- **NIO anti-frost electronic system activation**
- with parameter configuration in advanced mode, **the selections and settings can be password-protected** to prevent unauthorised personnel from changing them

## Ditec Qik ACCESSORIES ARE EASY TO CHOOSE

### Arms

- elliptic aluminium L = 3700, 5000 and 6000 mm
- round aluminium L = 3975
- joints for elliptic or round arm



### Balancing springs

- 4 springs for QIK7EH
- 1 spring for QIK80EH



### Batteries

battery kit for 24 VDC barrier



### Supports

- mobile, to fasten to the arm
- fixed, to fasten to the ground
- fixed, to fasten to the ground with electromechanical locking device



### Lights kit

- lights kit - 6 LEDs
- expandable up to 12 LEDs for QIK7EH
- expandable up to 15 LEDs for QIK80EH



### MD2 display module

for diagnostics and advanced management







**24V**  
ENCODER

**SAFE**

24 VDC version with encoder and limit switch provides speed regulation, possibility to use batteries and continued operation.

SETTING

**VERSATILE**

From the control panel, it is possible to precisely manage position and speed at all times, allowing adjustment for acceleration, deceleration, start time, slowdown distance and approach speed during opening and closing.

## Example of installation

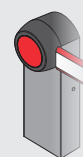

Installation diagram applicable also for the Ditec Qik 7EH version.

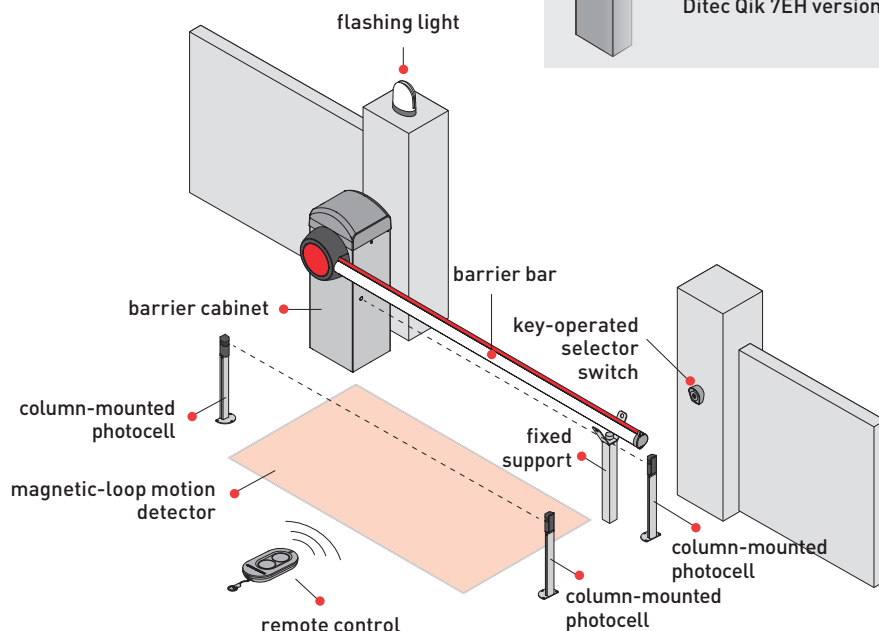

Discover the entire range of Ditec brand products at [www.ditecentrematic.com](http://www.ditecentrematic.com)!

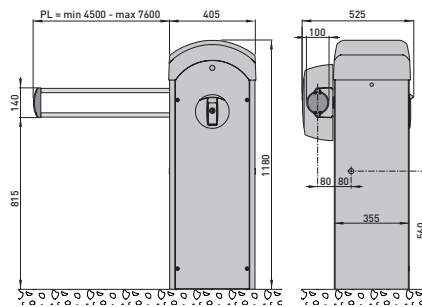
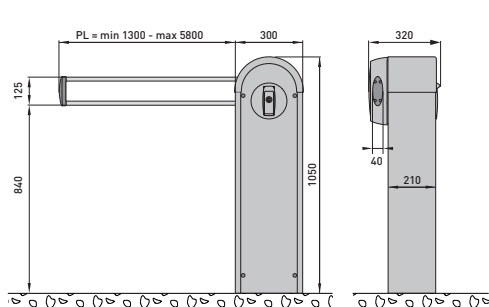

## Technical specifications

Description	Qik 7EH	Qik 80EH
Barriers	up to 5.8 m	up to 7.6 m
Stroke control	encoder	encoder + limit switch
Arm length up to	6 m	7.95 m
Arm	elliptic	round
Duty class	5 - very heavy	4 - heavy duty
Intermittent operation	S2 = 60 mins - S3 = 60%	S2 = 50 mins - S3 = 50%
Power supply	230 V AC/50-60 Hz	230 V AC/50-60 Hz
Power input	1 A	1.2 A
Torque	70 Nm	200 Nm
Opening and closing time	2÷6 s/90°	6÷12 s/90°
Release system for manual opening	key-operated	key-operated
Operating temperature	-20°C / +55°C [-35°C / +55°C with NIO activated, -10°C / +50°C with batteries]	
Protection rating	IP 24D	IP 24D

## Main functions of the system

Description	Qik 7EH	Qik 80EH
Control panel	ref. EL31R with built-in radio	ref. EL34 con decodificatore radio incorporato *
Mains power supply	230 V AC/50-60 Hz	230 V AC / 50/60 Hz
Batteries	■ (optional)	■ (optional)
Accessories power supply	24 V DC/0.3 A	24 V DC/0.5 A
Electro-mechanical lock	24 V DC/1 A	24 V DC/1 A
Flashing light	24 V DC	24 V DC
Gate-open warning light	analogue	analogue
Courtesy light	■	■
Designed to accommodate limit switch	■	■
Encoder to control speed and deceleration		■
Force setting	automatic	automatic
ODS - Obstacle Detection System		■
Speed setting	■	■
Braking/slowing down	■	■
Time setting		
Open control	■ (with dip-switch)	■
Partial opening control		
Close control	■	■
Timer-controlled automatic closing	■	■
Inching control	■	■ (with dip-switch)
Hold-to-run control	■	■
Emergency stop	■	■
Emergency reverse	■	■
Safety-test function	■	
Soft Start	■	
Immediate closing after transit	■	■
NIO - Antifreeze system	■	■
Protection rating	IP 55	IP 55

\*Note: add the GOLR receiver card for use with Entrematic ZEN remote control



### Entrematic Italy S.p.A.

Largo U. Boccioni, 1 • 21040 Origgio (VA) • Italy

Tel +39 02 963911 • Fax: +39 02 9650314

ditec@entrematic.com

www.ditecentrematic.com • www.entrematic.com

Cod. N212B - 04/2017

Ditec Qik

gdp milano 169865

RED APPLE INTERNATIONAL

Present in: France, Germany, Spain, Turkey and Canada.

For addresses and contact information see our website [www.ditecentrematic.com](http://www.ditecentrematic.com)

